



**J**ema Autolife A/S  
we are here to surprise!

**Model No. JA2000J**

Jack

Manual or Pneumatic Release

Lifting Capacity **2000KG**

**ORIGINAL**

**Installation, Operation  
and Parts Manual**

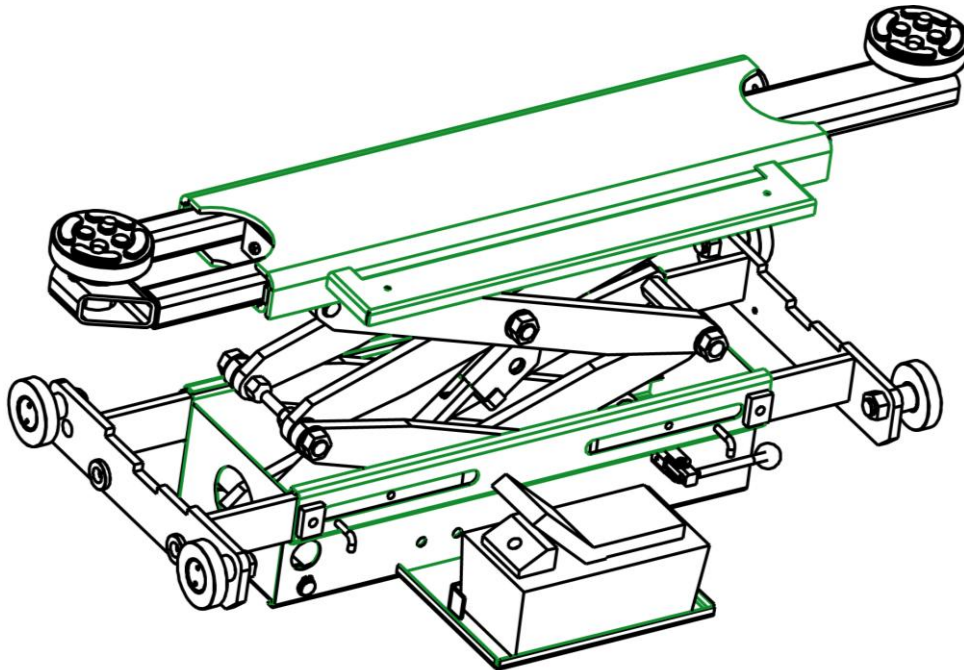

*Distributed by*

*Please read this entire manual carefully and completely before installation or operation of the jack.*

---

**INDEX**

<b>1. Important safety instructions.....</b>	<b>3~4</b>
1.1 Important notices	
1.2 Qualified personnel	
1.3 Danger notices	
1.4 Warnings	
<b>2. Overview of the lift.....</b>	<b>5~6</b>
2.1 General descriptions	
2.2 Safety construction	
2.3 Construction of the jack	
2.4 CE and name plate	
2.5 Optional parts	
<b>3. Installation instructions.....</b>	<b>7~8</b>
3.1 Preparations before installation	
3.2 Precautions for installation	
3.3 Installation	
3.4 Items to be checked after installation	
<b>4. Operation instructions.....</b>	<b>9~10</b>
4.1 Precautions	
4.2 Flow chart for operation	
4.3 Operating instructions	
<b>5. Trouble shooting.....</b>	<b>11</b>
<b>6. Maintenance.....</b>	<b>12</b>
<b>7. Annex.....</b>	<b>13~19</b>
Annex1, Overall diagram	
Annex2, Hydraulic working system	
Annex3, Separated drawings	
Annex4, Spare parts list	

## IMPORTANT SAFETY INSTRUCTIONS

### 1.1 Important notices

We will offer one-year's quality warranty for the whole machine, during which any quality problem will be properly solved to the user's satisfaction. However, we will not take any responsibility for whatever bad consequence resulted from improper installation and operation, overload running or unqualified ground condition.

Users must always bear in mind that this jack is specially designed for lifting cars or other vehicles, so never use it for any other purposes. Otherwise, Jema Autolifte and as well as our distributors, will not bear any responsibility for accidents or damages of the product.

Read this manual carefully before operating the jack to avoid economic loss or personnel casualty incurred by wrong operation. The consumer may under no circumstances change the construction on the jack, if this should occur disclaims Jema Autolifte all liability and warranty canceled with immediate effect.

### 1.2 Qualified personnel

1.2.1 Only properly trained personnel can operate the jack.

1.2.2 Air connection must be made by qualified personnel to avoid injury.

1.2.3 Not trained personnel should leave the area during the use of the jack.

### 1.3 Danger notices

1.3.1 Read and understand all safety warnings before operating.

1.3.2 Keep hands and feet away from any moving parts.

1.3.3 Only properly trained personnel can operate the jack.

1.3.4 Do not wear inappropriate clothing such as excessive clothing, clothing with loose parts, etc., which can get caught in moving parts.

1.3.5 Always ensure that the jack is in safety lock before any attempt to work near or under the vehicle. Never remove safety related components from the jack. The jack should not be used if safety related components are damaged or missing.

1.3.6 The vehicle must not be moved while the vehicle is raised on a jack or removing heavy components from the vehicle, which can cause that the weight distribution of the vehicle is changed radically.

1.3.7 The user may under no circumstances subside functional changes or product changes if the unlikely event occur, declines Jema Autolifte all responsibility and liability invalid, as it may seriously cause equipment and personal damages.

## 1.4 Warnings

1.4.1 Always keep a close eye on how that can be possible to turn heads when you're under the vehicle to prevent injury.

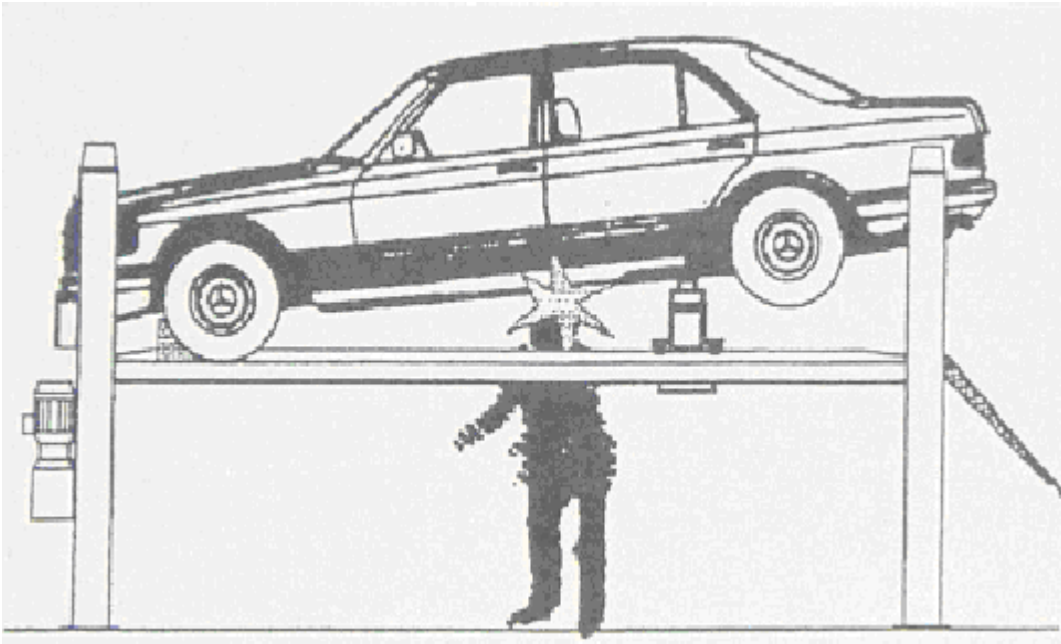

1.4.2 It is forbidden to stand on the jack or use it for anything other than the designated purpose.

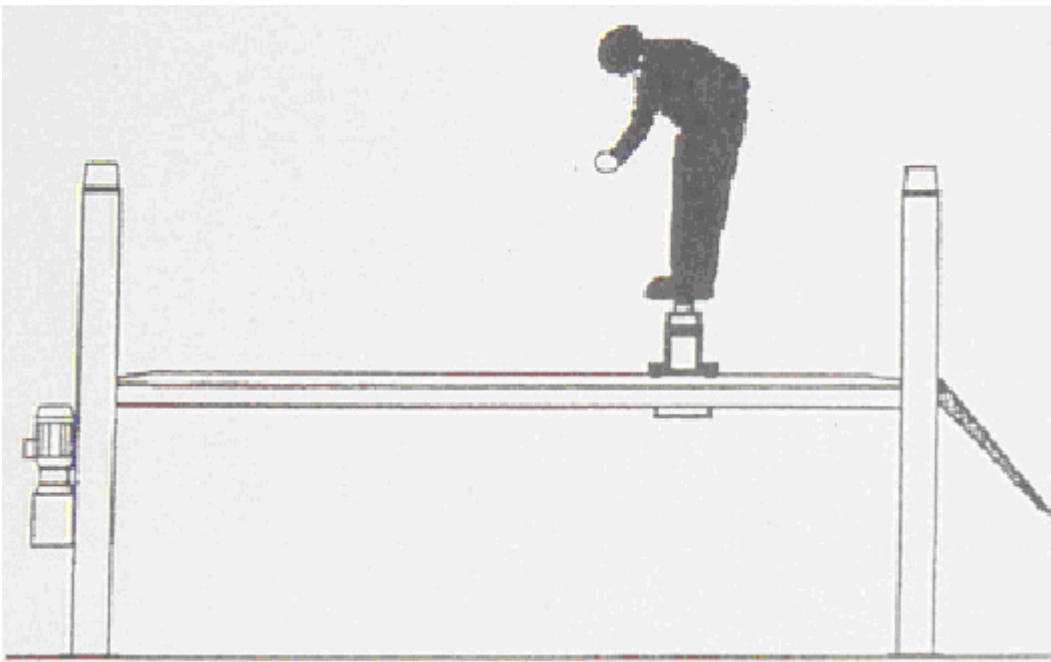

## OVERVIEW OF THE JACK

### 2.1 General description

The jack is mainly composed of Sax, lifting platform, base, oil piston, pump.

The jack may act on the one manner, in order of the model selected by the user.

#### 1. Air hydraulic pump (JA2000J-AIR)

The pressure from the pump or pump station pushes oil into the piston which put the piston in motion so that the vehicle can be lifted to the height of the user selects. During the lifting process will the jacks safety locks automatically work and make sure if a possible leak in the hydraulic system should accrue will the user will not get hurt and the vehicle will remain in the position the safety locks is in.

To meet user needs, Jema Autolifte developed 3 different jack models in our Basic line series.

#### Model 1: Hydraulic pneumatic pump

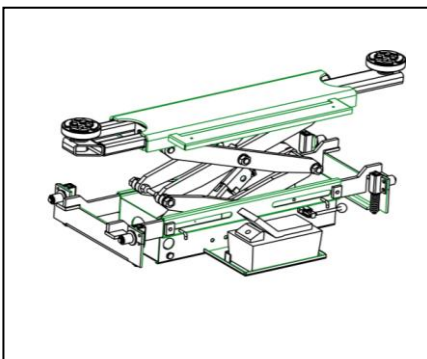

### 2.2 Safety structure

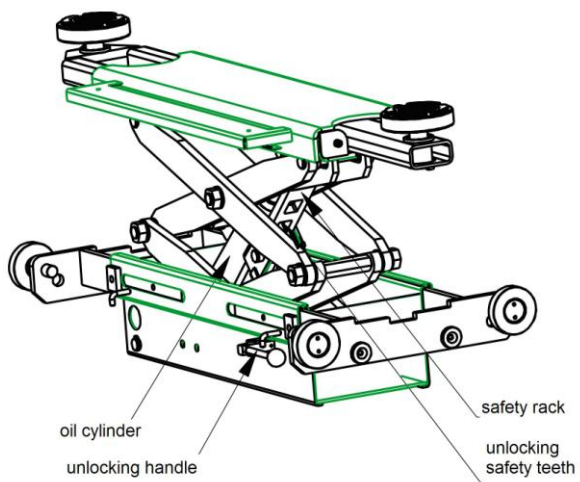

## 2.3 Construction of the lift

1. Beam    2. Base    3. Moving bracket    4. Supporting frame    5. Pneumatic pump    6. Oil cylinder

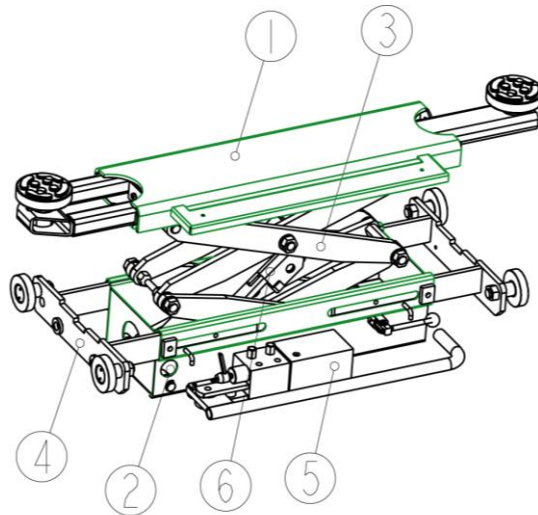

## 2.4 CE and name plate

Check the maximum Capacity and air pressure on the rating plate on the jack. Do NOT lift beyond max lift capacity under no circumstances when use of the jack. The serial number and date of manufacture will show the user when the jack need service. Call the distributor when service must be performed.

## 2.5 Optional parts

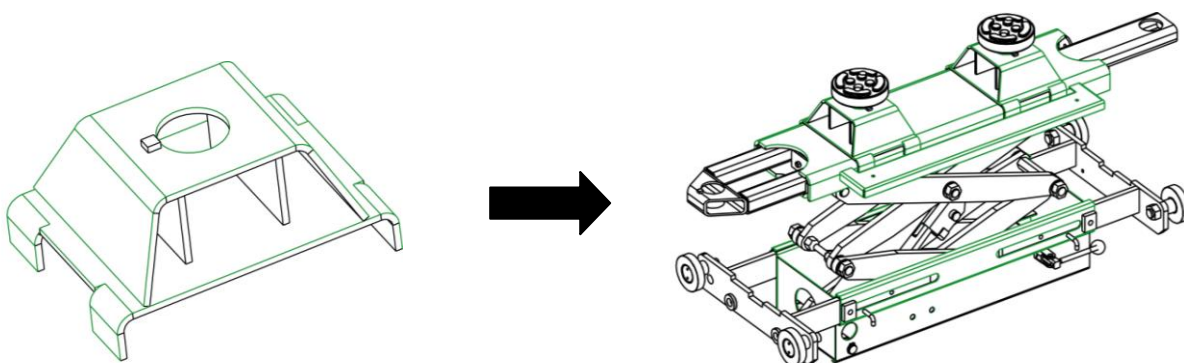

## INSTALLATION INSTRUCTIONS

### 3.1 Preparations before installation

- ✓ Appropriate lifting equipment
- ✓ 14# open spanner

### 3.2 Precautions for installation

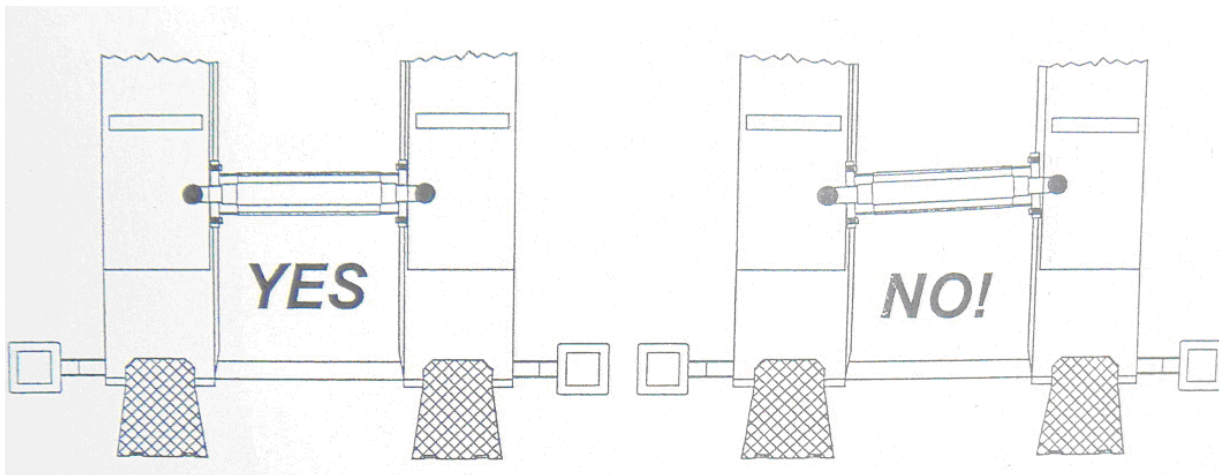

### 3.3 Installation instructions

**Step1:** Take the jack out of the transport box

**Step2:** Use proper lifting tools to have the jack placed onto the lift.

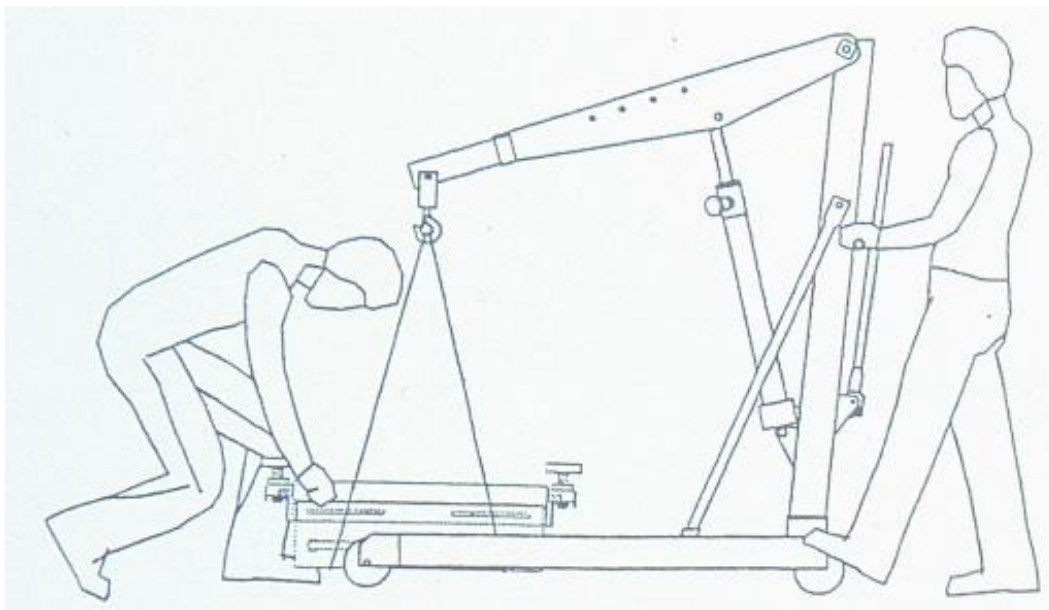

**Note:** Installation methods are different for different types of the jack.

(Hydraulic pneumatic)

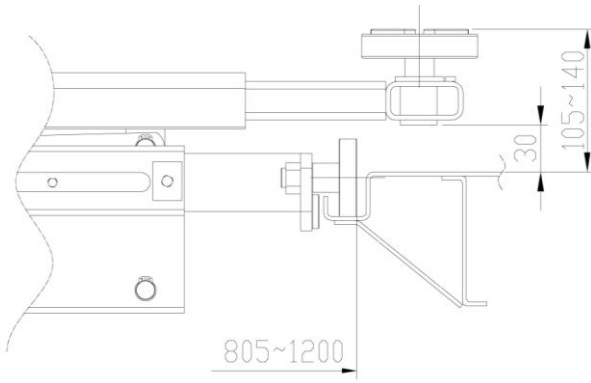

JA2000J-AIR: Connect the air hose (It is only necessary to jack with pneumatic hydraulic pump)

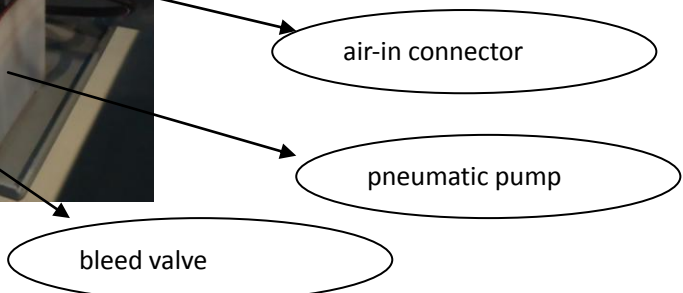

The end user need to prepare  $\varnothing$  8mm air hose. Length of the hose is decided by practical use.

Connect one end of the hose to the air-in connector on the pump and the other end to the air supply equipments.

(Air pressure: 6~8kg/cm<sup>2</sup>)

Loosen the bleed valve before taking the jack in use. If the user does not do this, the hydraulic pump break and it will not be covered under warranty.

### 3.4. Items to be checked after installation.

S/N	Check items	YES	NO
1	If the roll wheels of the jack could move easily in the track?		
2	If the jack is slant?		
3	If all the connections are firm and reliable ?		
4	If it is grease as being required?		



## OPERATION INSTRUCTIONS

### 4.1 Precautions

4.1.1 Check all the joints of oil hose. Only when there is no leakage, the jack can start work.

4.1.2 The jack, if its safety device malfunctions, shall not be used.

4.1.3 Operators and other personnel concerned should stand in a safety area during lifting and lowering process.

4.1.4 Only when the jack has been raised to a proper height can the operator use the jack.

4.1.5 Make sure the safety lock of the jack is engaged before start working under the vehicle and during lifting and lowering process, height of operator must be lower than platform of the lift.

### 4.2 Operation instructions

#### 4.2.1 Operation instructions of the hydraulic pump

##### 1. Pneumatic pump

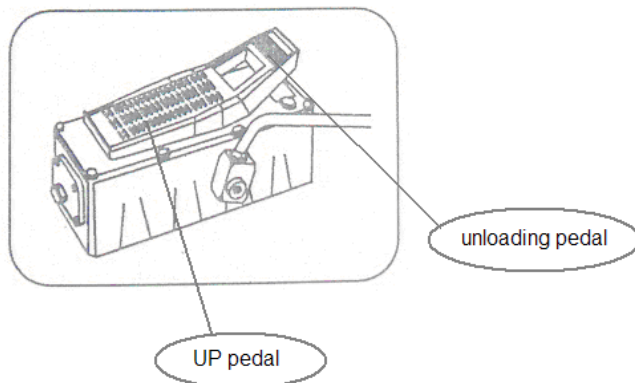

**DANGER:** When raise the jack to proper height, it is necessary to press the unloading valve to have the safety lock engaged before doing any service work.

**ATTENTION:** After service work finished, raise the jack to release the safety lock first and then press the unlocking handle and manual unloading valve to lower the jack.

#### 4.2.2 Raise and lower the jack

##### Raise the jack

1. Make sure the operation manual is well understood before operation.

2. Move the lifting tray to proper pick-up points.

3. **JA2000J-AIR:** Press the lever on air hydraulic pump to lift the jack.

4. **JA2000J-AIR:** When the jack has reached the desired height press return valve on the air hydraulic pump to make sure the jack goes into the safety lock before the user begins his work on the vehicle.

## Lower the jack

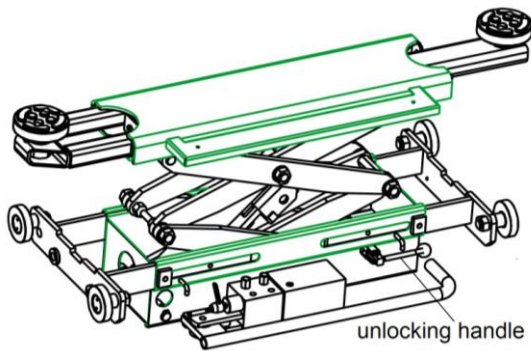

1. **JA2000J-AIR:** Press the lever on air hydraulic pump to lift jack off the safety lock.
2. Pull the unlocking handle.
3. **JA2000J-AIR:** Press on return valve on the pump and the jack is lowering.

## TROUBLE SHOOTING

**ATTENTION:** If the trouble could not be fixed by the user, please do not hesitate to contact the distributor for help. We will offer our service at the earliest time we can. Troubles will be judged and solved much faster if more details or pictures can be provided.

TROUBLES	CAUSE	SOLUTION
Abnormal noise	Trash in the track	Clean
Unloading after being raised	Oil hose leak	Change oil hose
	Cylinder seals bad	Change seal components
	Single-way valve seal bad	Dismantle and clean or replace with a new one
	Overflow valve does not work	Dismantle and clean or replace with a new one
	Soul performance of solenoid unloading valve	Dismantle and clean or replace with a new one
Raise too slow	Oil filter plugged	Dismantle and clean or replace with a new one
	Air in the oil	Add more oil
	Overflow valve not adjusted well	Adjust
	Temperature of oil high than 45°	Change oil
	Seal ring abraded	Change seal components

## MAINTENANCE

By complying with the statutory servicing can be sure your Jema Autolifte jack will operate safely and with minimal maintenance. Jema Autolifte jack should be made mandatory servicing 1 annually - You can contact your Jema Autolifte distributor service department.

Positions need to be greased.

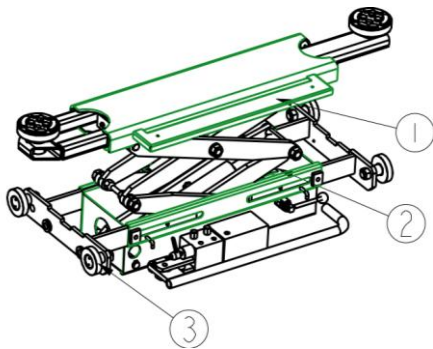

S/N	Name
1	UP rotor shaft
2	Rotor wheel
3	Roll wheel

### 6.1 Daily checking items before operation

The user must perform daily check. Daily check of safety lock system is very important – the discovery of device failure before action could save your time and prevent you from great loss, injury or casualty.

- . Judge whether the safety latches are engaged by sound.
- . Check whether oil hose well connected and whether it leaks or not.

### 6.2 Weekly checking items

- . Check the flexibility of moving parts.
- . Check the working conditions of safety parts.

### 6.3 Monthly checking items

- . Check the tightness of hydraulic system, screw tight the connectors.
- . Check the abrasion of moving parts.

**If the above maintenance requirements are strictly followed, the jack will keep in a good working condition and meanwhile accidents could be avoided to a large extent.**

## ANNEX

### Annex1, Overall dimension

#### 1. JA2000J-AIR

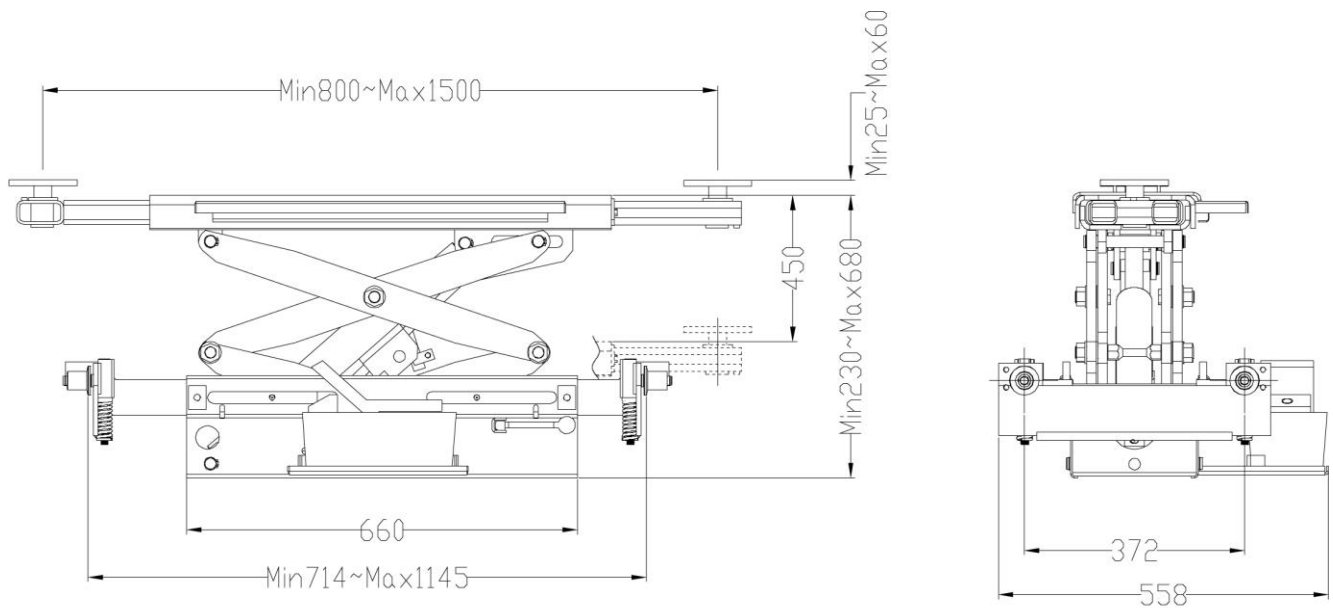

**Annex2, Hydraulic system**

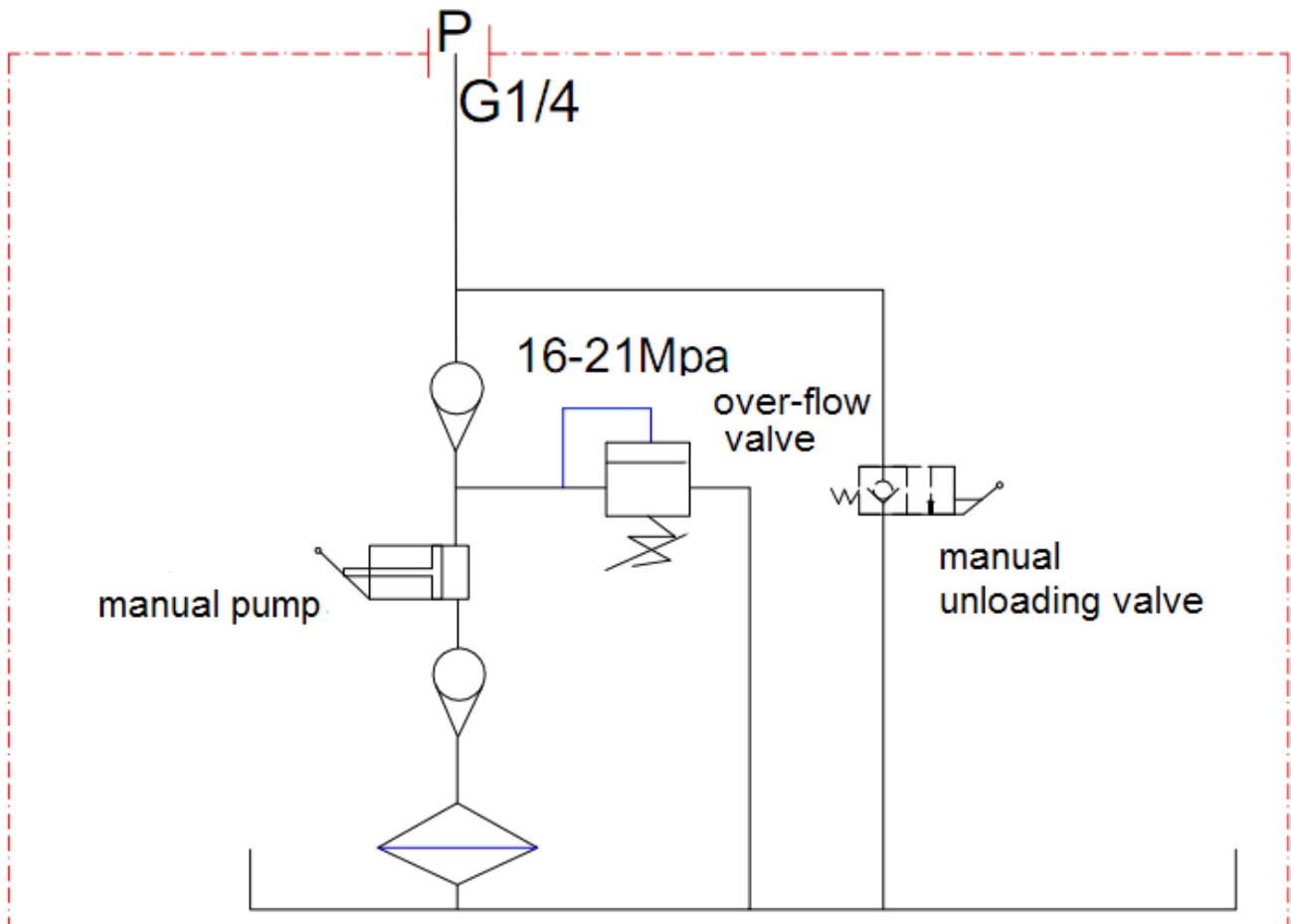

## Annex3, Separated drawings

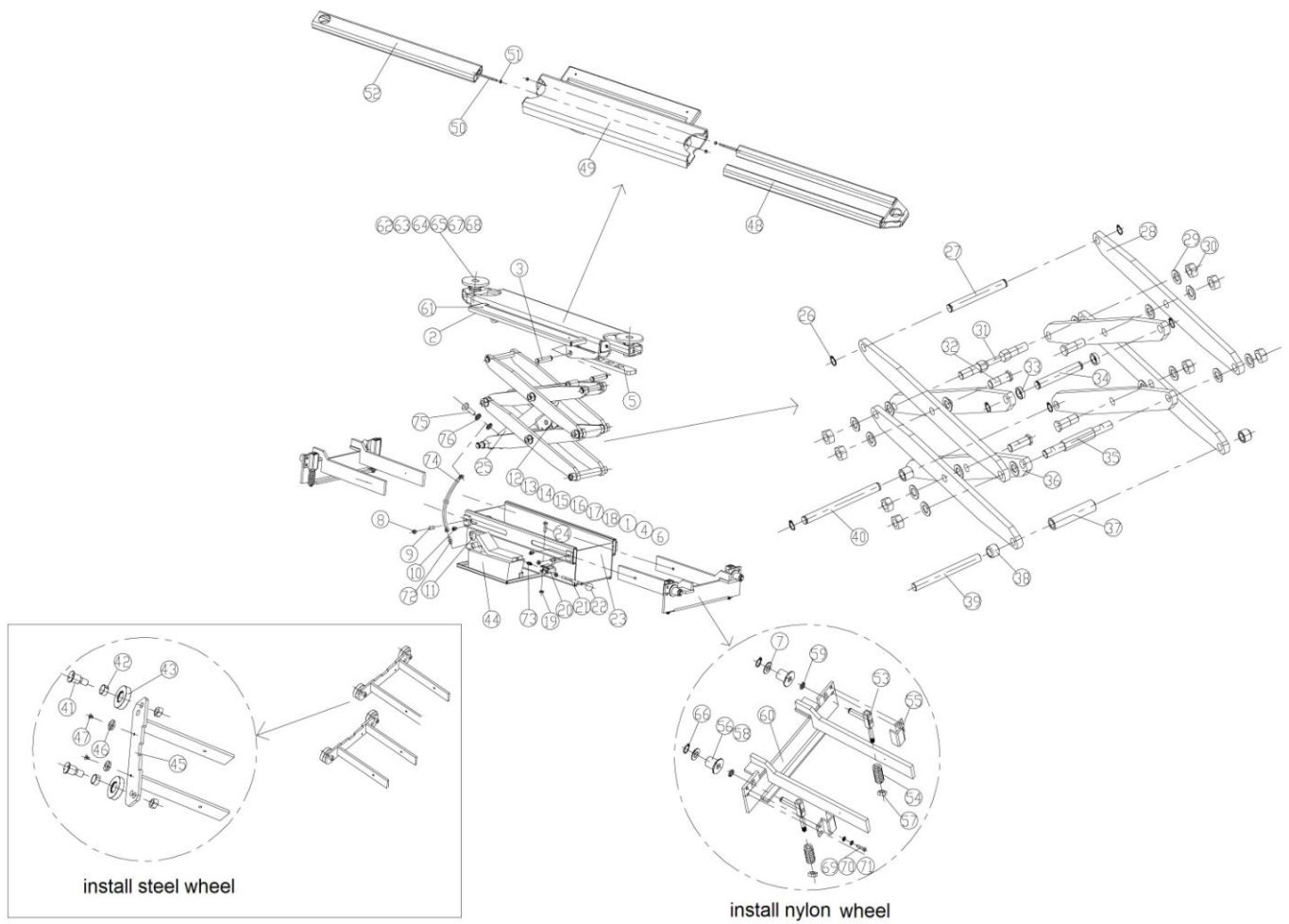

S/N	Material #	Name	Specification (drawing#)	Qty	Note
1	204101005	Flat washer	M8	5	
2	615028017	Protection cloth	60*65	1	
3	410280291	Shaft of oil cylinder	CJ-A12-B5-C2	2	
4	203103006	Non-metallic lock nut	M8	2	
5	612028003	Safety rack assembly	CJ-A12-B5-C4	1	
6	208101003	Brake cable	Rubber L1=940, steel cable L2=1080	1	
7	204101009	Flat washer	M16	4	
8	203101007	Hex nut	M12	4	
9	202206004	Inside hex tapping screw	M12*30	4	
10	202109039	Inside hex cylinder head screw	M10*8	4	
11	420040030	40 hose clip	6254E-A21	1	
12	410280301	Mid shaft of oil cylinder	CJ-A12-B5-C5	1	
13	612028002	Safety block	CJ-A12-B5-C3	1	
14	410280311	Small shaft 2	CJ-A12-B5-C6	1	
15	410280321	Positioning rod	CJ-A12-B5-C7	1	
16	410280401	Spring	CJ-A12-B5-C11	1	
17	204301013	Circlip	M38	1	
18	410281150	Grip screw	CJ-A12-B5-C14	1	
19	203101006	Hex nut	M10	1	
20	410280331	Positioning plate	CJ-A12-B5-C8	1	
21	410280341	Handle	CJ-A12-B5-C9	1	
22	208105001	D32 handle ball	Red	1	
23	614028019		CJ-A12-B4		
	614028024	Base (pneumatic)		1	JA2000J-AIR
24	201102022	Hex head full swivel screw	M10*45	1	
25	615028014	Oil cylinder	CJ-A12-B5-C1	1	
26	204301007	Circlip	M20	12	
27	410280241	Shaft A	CJ-A12-B3-C8	1	
28	410280033	Moving bracket	CJ-A12-B3-C1	6	
29	204101011	Flat washer	M20	16	
30	203103012	Nonmetallic hex head lock nut	M20	12	
31	410280221	Connection shaft B	CJ-A12-B3-C5	1	
32	410280191	Mid shaft	CJ-A12-B3-C2	4	
33	410280251	Spacer ring	CJ-A12-B3-C9	2	
34	410280201	Shaft B	CJ-A12-B3-C3	1	
35	410280211	Connection shaft A	CJ-A12-B3-C4	1	
36	614028017	Moving bracket(left)	CJ-A12-B3-C7	1	
	614028018	Moving bracket(right)		1	
37	410280271	Mid bushing	CJ-A12-B3-C11	1	
38	410280281	Roll wheel	CJ-A12-B3-C12	2	
39	410280261	Connection shaft D	CJ-A12-B3-C10	1	
40	410280231	Connection shaft C	CJ-A12-B3-C6	1	
41	410280351	Shaft	CJ-A12-B6-C2	4	
42	205101016	Bearing SF-1	3015	4	
43	410280361	Roll wheel	CJ-A12-B6-C3	4	



S/N	Material #	Name	Specification (drawing#)	Qty	Note
44	615028002	Pneumatic pump		1	JA2000J-AIR
	615028001		CJ-A12-B9		
45	614028020	Supporting frame A	CJ-A12-B6-C1	2	
46	420280010	Sheath	CJ-A12-B6-C4	4	
47	202111004	Inside hex sunken head screw	M8*12	4	
48	614028015	Welded square tube A	CJ-A12-B1-C2	1	
49	614028014	Beam assembly	CJ-A12-B1-C1	1	
50	410280171	Positioning rod	CJ-A12-B1-C4	2	
51	203101005	Hex nut	M8	4	
52	614028016	Welded square tube B	CJ-A12-B1-C3	1	
53	612028004	Welded rod	CJ-A12-B7-C2	4	
54	410280421	Compressed spring	CJ-A12-B7-C6	4	
55	614028022	Positioning plate (left)	CJ-A12-B7-C7	2	
	614028025	Positioning plate (right)		2	
56	205101042	Needle bushing	HK1516	8	
57	203103008	Nonmetallic hex lock nut	M12	4	
58	420280020	Positioning sheath	CJ-A12-B7-C5	4	
59	410280371	Spacer ring	CJ-A12-B7-C3	4	
60	614028021	Supporting bracket B	CJ-A12-B7-C1	2	
61	202101027	Cross cap screw	M6*8	2	
62	410280181	Inside swivel sheath	CJ-A12-B2-C1	2	
63	612004002B	Lifting tray	6254E-A7-B4-C1	2	
64	410040041	Swivel sheath	6254E-A7-B4-C2	2	
65	420040050C	Round lift pad	6254E-A7-B4-C4	2	
66	204301004	Circlip	M15	4	
67	204302003	Circlip	M26*M2	1	
68	204302004	Circlip	M38*M2.5	2	
69	204201005	Spring washer	M10	8	
70	204101006	Flat washer	M10	8	
71	201102017	Hex head full swivel screw	M10*20	8	
72	410280011	Pneumatic pump connector	SCJ-A8	1	JA2000J-AIR
73	310101015	Fast oil hose connector	KLC8-02	1	JA2000J-AIR
74	624002007		CJ-A12-B5-C13		
	624002021	Oil hose L=400mm		1	JA2000J-AIR
75	410281130	Oil cylinder connector	CJ-A12-B5-C10	1	JA2000J-AIR
76	207103019	Composition washer	M14	2	JA2000J-AIR

S/N	Material #	Name	Specification (drawing#)	Qty	Note
1	207103019	Composition washer	M14	1	
2	615028001	Manual pump	CJ-A12-B9	1	
3	615028002	Pneumatic pump		1	
4	420040050C	Round lifting pad	6254E-A7-B4-C4	2	

5	207104004	U-shape ring	KD50*40*10	1	
6	207105012	Anti-dust ring	DHS30(30*38*516.5)	1	
7	207101023	O-shape ring	40*5.3	1	
8	207101024	O-shape ring	23.6*3.55	1	
9	207101025	O-shape ring	48.7*3.55	1	
10	207106009	Anti-abrasion ring	BS50703-0500A-47	1	
11	207106010	Anti-abrasion ring	BS50703-0300C-47	1	
12	208101003	Blake cable	Rubber L1=940, steel cable L2=1080	1	

# CE Declaration of Conformity CE

## (Manufacturer's Declaration)

We: **Jema Autolifte CO., LTD** - Lixianzhuang Industrial Zone, Shangma, Chengyang, Qingdao, Shandong, 266000, P.R.China

declare in sole responsibility that the equipment

**Vehicle Lift** JA2000J.

to which this declaration applies, complies with these normative documents:

2006/42/EC

2006/95/EC

2004/108/EC

EN 1493:2010

EN 60204-1: 2006+A1+AC

This declaration is based on: Third party testing, performed by the Notified Body TÜV Rheinland, Product Safety GmbH (Registration Number 0197)

TÜV Rheinland registration no.: BM 50311035 0001

TÜV Rheinland report Nr. : 17706531 001

### Notes:

This declaration becomes invalid, if technical or operational modifications are introduced without the manufacturers consent.

Name and address of the person (established in the Community) compiled the technical file:

Kasper Petersen, Industrihegnet 2, 4030 Tune, Denmark.....

Responsible for making this declaration is the :

Manufacturer  Authorized representative established within the EU

Person responsible for making this declaration

Name ,Surname : **Sarah Ren**.....

Position/ Title : **Business Manager**.....

Qingdao : 02,Nov,2014.....

(place)

(date)

(company stamp and legal signature)

